

FRONT VIEW

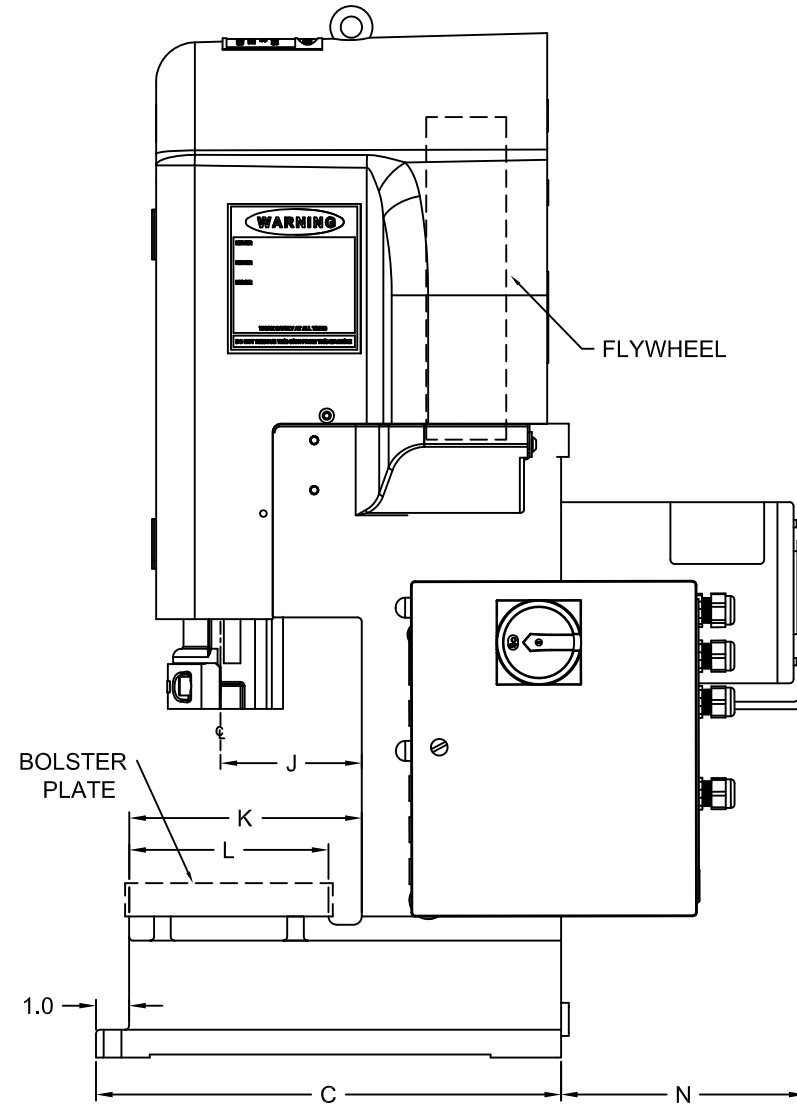

RIGHT SIDE VIEW

DIMENSIONS FOR REFERENCE ONLY  
(INCHES)

PRESS	3K-7	5K-7	5K-9
A	11.38	13.13	13.13
B	28.56	28.25	30.25
C	12.50	14	14
D	10	12	12
E	7.13	9.13	9.13
F	7	7	9
G	4	4.25	4.25
H	4.38	6.88	6.88
J	3.84	4.22	4.22
K	6.50	7	7
L	5.50	6	6
N	7	7.50	7.50
P	4.31	6.13	6.13
R	10.88	12.13	12.13
T	6	8	8
U	.63	.75	.75
V	8.75	10.50	10.50
W	3.50	4	4
X	2.81	2.62	2.62
Y	4.38	6.76	6.76
Z	1.38	1.06	1.06
a	4.13	3.88	3.88
b	1.66	1.78	1.78
c	.28	.34	.34
d	1	1.56	1.56
e	.16	.09	.09
f	3.25	4	4
g	4	4.75	4.75
h	4.75	5.50	5.50

NOTE:  
3K-7 300 SPM  
5K-7 & 5K-9 285 SPM

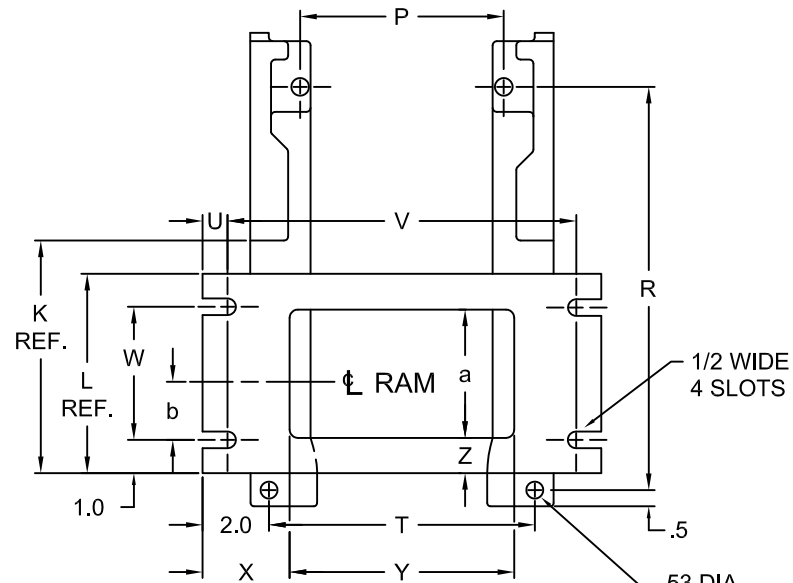

VIEW BB - BB

BOLSTER AREA & MOUNTING HOLES

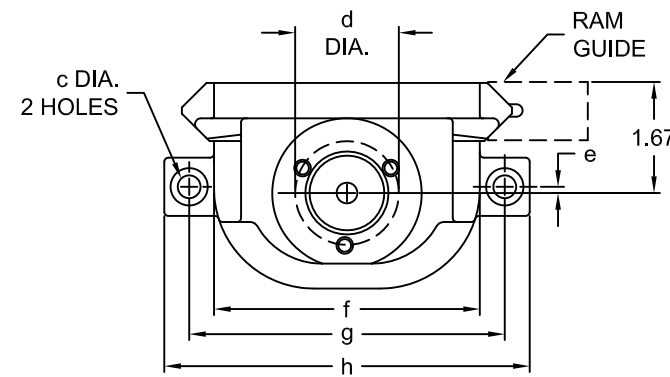

RAM DETAIL

SCALE: 2:1



Manufactured by:  
TABER Industries  
455 Bryant Street  
North Tonawanda, New York 14120  
Phone: 716.694.4000 / Fax: 716.694.1450  
Email: info@kencopress.com  
www.kencopress.com